



1. In awarding Liquor Expresses (LE) to proponents the NLC
  - a. Will generally not permit a LE to be established in motels, hotels, restaurants, licensed establishments; and
  - b. Will generally award LEs to persons with already existing businesses.
  - c. Only staff over 19 years of age are eligible to sell product.
2. LEs will be responsible for providing, at their expense, all interior design, renovation, and finish for the LE operations, in accordance with NLC standards. All operating expenses and costs will be the responsibility of the LE. Details of financial and spacing requirements are attached as Schedule A.
3. The LE will be required to carry an appropriate brand selection, as determined by the NLC, and will be required to have adequate retail and warehouse space, in the opinion of the NLC, to accommodate this selection.
4. The LE will purchase the products from the NLC on a payment basis acceptable to the NLC. The purchase price will be the regular retail price of the goods, less the LE commission.
5. The commission is as follows:
  - a. 10.3% on sales up to \$250,000; and
  - b. 5.15% on sales exceeding \$250,000 in any fiscal year of the NLC.
6. The LE will, if required by the NLC, pay the purchase price on delivery of the goods.
7. The LE will, if required by NLC, provide security acceptable to the NLC for the payment of the purchase price.
8. The NLC will deliver the product to the LE at schedules established by the NLC, and the NLC will bear the freight cost.
9. The LE will be required to report monthly/quarterly to the NLC, and the NLC will supply the necessary reporting forms and operating instructions.
10. The LE will operate as a self-service outlet.

11. The Liquor Express will be required to meet minimum technology requirements. This includes a PC/Laptop with licensed Antivirus software, POS and an active internet connection.
12. The applicant shall complete fully the attached application.
13. The NLC will perform certain background checks on prospective applicants, including, but not limited to the following:
  - a. Credit checks.
  - b. Financial information review from the applicant's financial institution or institutions;
  - c. Certificates of Conduct or equivalent from police authorities;
  - d. Where necessary, corporate searches respecting the name, existence, and directors of the corporation.
  - e. Searches of the Personal Property Securities Registry.
  - f. Searches of the Judgment Enforcement Registry; and
  - g. Searches, where necessary, of other registries and government authorities that record liens or potential liens against.
  - h. Where necessary, the applicant will be required to sign a consent or authorization necessary for such authorities to release information to the NLC.
14. The applicant, if a corporation, will be required to:
  - a. provide with the application an Officer's Certificate in form annexed hereto as Schedule C
15. The applicant will be evaluated based on a scoring grid. Topics evaluated include:
  - a. Location – 15 points
  - b. Premises – 25 points
  - c. Operations – 40 points
  - d. Interview – 15 points
  - e. Financials – 15 points
  - f. Review for existing Liquor Express – 10 pointsTotal achievable points – 120
16. Applicant will be required to provide annual sales, annual beer sales if applicable, customer transaction count and sales trend.

17. The successful applicant will be required to sign a Liquor Express Agreement for a five-year term and provide insurance documentation in form acceptable to the NLC.
18. Successful applicant will be required to adhere to NLC's Check 25 program. This includes annual training and monthly submissions. Monthly submissions will be submitted through NLCs Liquor Express portal.
19. Further details will be made available by the NLC's authorized representative during the site visit and inspection.

**NOTWITHSTANDING ANYTHING CONTAINED HEREIN, THE NLC SHALL NOT BE REQUIRED, AS A RESULT OF THE ADVERTISING FOR A LIQUOR EXPRESS, TO AWARD A LIQUOR EXPRESS OUTLET TO ANY APPLICANT, AND RESERVES THE RIGHT TO CANCEL THE REQUEST FOR PROPOSALS AND/OR READVERTISE AND/OR SELECT ANY SUITABLE PERSON OR CORPORATION, WHETHER AN APPLICANT OR NOT, FOR THE OPERATION OF THE LIQUOR EXPRESS.**



### **SECTION A – Applicant CHECKLIST**

- Applicant answered all questions completely in Section A, B, C, D & E.
- Applicant faxed the CRA Clearance Request to **709-754-5928**
- Applicant Included fax confirmation sheet from CRA
- Applicant will email or fax CRA clearance letter no later than 2 weeks from the advertisement end date.
- Applicant Included three (3) completed Business Reference forms (Appendix A)
- Completed the Personal History Report – Section C (ALL applicants partners & shareholders)
- Applicant will email or fax Criminal Records Screening Certificates (ALL applicants) no later than 2 weeks from the advertisement end date.

#### **Please forward application to:**

Liquor Express Sales Specialist/Business Development  
Newfoundland and Labrador Liquor Corporation  
P.O. Box 8750, Station A  
St. John's, NL A1B 3V1  
[donna.hudson@nliquor.com](mailto:donna.hudson@nliquor.com)  
Fax: (709) 724-2250

**Note:** Applications will NOT be accepted unless all required documentation has been completed. Please ensure you review the checklist. Missing information can cause delays with processing your submission and applications sent after the closing date deadline will not qualify.

\_\_\_\_\_  
Date

\_\_\_\_\_  
Signature of Applicant



**Please read the following carefully:**

There are five sections to this application – Section A (Checklist), B, C, D and E. Failure to complete any or all sections may result in rejection of the application.

Upon receipt, the information contained is deemed CONFIDENTIAL.

The word “applicant” means the corporation or the persons or the person who will be appointed Operator and on whose behalf this application is made.

If the applicant is a corporation, the president must complete the application; in the case of a partnership, each partner must sign the application; in the case of a sole proprietorship, the owner must sign the application.

If additional copies of Sections B & C are required, the applicant should photocopy that section for use in completion of the application.

**SECTION B - BUSINESS HISTORY REPORT**

**Please Print**

1. Area Applied for As Advertised:

2. Business Name of Establishment:

3. If operating under another name please list it below:

4. Company Number:

5. CRA Number:

6. Location of Establishment:

--

7. Physical Address:

Postal Code

*(Please be sure to include the street # in address)*

8. Mailing address:

Postal Code

*(Please be sure to include the street #, if applicable, in address)*

9. Business Establishment

Telephone Number:

Fax Number:

E-Mail Address

--	--	--

10. Telephone Number Where Applicant Can Be Reached During Business Hours:

--

11. Names of Applicants (Sole owner or partners or officers of a corporation):

Name	Address

**NOTE: All applicants must fill out section B**

12. Is Applicant Sole Owner? \_\_\_\_\_ Yes \_\_\_\_\_ No

(a) If a partnership, list the percentage of ownership of each partner:

Name	Percentage

(b) If a corporation, give:

Date of Incorporation:
Public or Private Company:
Provincial or Federal Charter:
Number of Common Shares Authorized:
Number of Common Shares Outstanding:

List Shareholders:

Name	Address	No. of Common Shares Owned	No. of Preferred Shares Owned

13. Do any Shareholders have any direct or indirect financial interest in any enterprise which manufactures or sells alcoholic beverages, including a Brewers' Agent Licence?

\_\_\_\_\_ Yes \_\_\_\_\_ No

If yes, give details, including Brewers' Agent Licence No.:

\_\_\_\_\_

\_\_\_\_\_

\_\_\_\_\_

14. State whether applicant will occupy building as owner or tenant:

\_\_\_\_\_

*If premises are leased, enclose a copy of the lease.*

15. State particulars of any mortgage or charge to which the premises or chattels are to be subject, including the name of the financial institution holding the mortgage or charge:

\_\_\_\_\_  
\_\_\_\_\_  
\_\_\_\_\_  
\_\_\_\_\_

16. The premises are built of \_\_\_\_\_ and the age of the premises is \_\_\_\_\_ (type of construction) \_\_\_\_\_ years.

17. Briefly describe the types of business now carried on at the address given:

\_\_\_\_\_  
\_\_\_\_\_  
\_\_\_\_\_  
\_\_\_\_\_

18. Current Hours of Opening:

\_\_\_\_\_  
\_\_\_\_\_

19. What is your current annual sales volume? \_\_\_\_\_

20. What is your current beer sales volume? \_\_\_\_\_

21. What is your average weekly customer count? \_\_\_\_\_

22. What is your year over year sales trend growth? \_\_\_\_\_

19. Does this business currently use a POS system at the address given?



\_\_\_\_\_ Yes \_\_\_\_\_ No

If yes, please state the make and model.

---

---

20. In conjunction with what type of business will the Liquor Express store be operated?

---

---

---

21. Name of person who will manage the Liquor Express store:

---

22. Name, Address, and Date of Birth of persons who will be employed in the establishment, other than the Manager:

Name	Address
Date of Birth	Place of Birth
Name	Address
Date of Birth	Place of Birth

23. Has any person named in Question 21 ever been convicted of a criminal offence or breach of the Liquor Control Act?

\_\_\_\_\_ Yes \_\_\_\_\_ No

If yes, give details:

---

---

---

---

---

24. How long has the applicant carried on business at the address given?

---

25. How long has the applicant carried on business described in Question 17?

---

26. Give three business references. **Have your references complete the form included in Appendix A and submit each with your application.**

Please note – the business references need to be associated with the current business listed in this Liquor Express application and should be able to comment on the payment/credit status of your account(s), i.e. Grocery Supplier, Beer Vendors, Dairy Vendors, Gas Supplier, Lottery, Tobacco, etc.

Name:

---

Address: \_\_\_\_\_

Telephone No: \_\_\_\_\_ Fax No: \_\_\_\_\_

Name:

---

Address: \_\_\_\_\_

Telephone No: \_\_\_\_\_ Fax No: \_\_\_\_\_

Name:

---

Address: \_\_\_\_\_

Telephone No: \_\_\_\_\_ Fax No: \_\_\_\_\_

\_\_\_\_\_  
Date

\_\_\_\_\_  
Signature of Applicant

\_\_\_\_\_  
Date

\_\_\_\_\_  
Signature of Applicant (if required)

\_\_\_\_\_  
Date

\_\_\_\_\_  
Signature of Applicant (If required)



**SECTION C - PERSONAL HISTORY REPORT**

**Please Print**

**This form is to be completed by individual applicants, partners, or officers of a corporation applying for the Liquor Express. If additional forms are required, please photocopy this section. Upon completion, these reports are to be attached and will form part of the application.**

Name in Full: (Including middle name)	Surname: _____  Given Names: _____
Date of Birth: (year / month / day)	
Place of Birth:	
Home Address: (Including Street & Street #, P.O. Box, City, Town, and Postal Code)	
Home Telephone #:	
Fax #:	

**1. Place of Residence During the Past 10 Years:**

Place	Date

2. Details of Employment for the past 10 years:

Dates	Occupation	Location	Employer

3. Have you or any of your family ever been employed by the Newfoundland Labrador Liquor Corporation?

\_\_\_\_\_ Yes \_\_\_\_\_ No

If yes, give details:

---

---

---

---

4. Do you have any past or present, direct or indirect, financial interest in any enterprise which manufactures or sells alcoholic beverages, including a Brewers' Agent Licence?

\_\_\_\_\_ Yes \_\_\_\_\_ No

If yes, give details, including Brewers' Agent Licence No.:

---

---

---

---

5. Are there any civil court judgements, executions, liens, or similar obligations outstanding against you for any reason anywhere?

\_\_\_\_\_ Yes \_\_\_\_\_ No

If yes, give details:

---

---

---

---

6. Have you even been convicted of a criminal offence under the Criminal Code of Canada, or any offence anywhere involving drugs or gambling or any offence against any law of any province in Canada involving spirits, wine or beer?

\_\_\_\_\_ Yes \_\_\_\_\_ No

If yes, give details:

---

---

---

---

7. Have you, in your personal capacity or in your association with any group, company, or corporation, ever been the subject of bankruptcy proceedings?

\_\_\_\_\_ Yes \_\_\_\_\_ No

If yes, give details:

---

---

---

---

\_\_\_\_\_  
Date

\_\_\_\_\_  
Signature of Applicant

(NOTE – More than one applicant **please copy pages 12 to 14** and have all applicants/shareholders fill out Section C.)



**SECTION D – POLICE & FINANCIAL CLEARANCE AUTHORIZATION**

The Royal Canadian Mounted Police, The Royal Newfoundland Constabulary, or any other law enforcement agency, is hereby authorized to supply the Newfoundland Labrador Liquor Corporation with any information which the Corporation considers pertinent to my application for a Liquor Express store.

**Please Print:**

---

Last Name Given Names

---

Date of Birth Year Month Day

---

Signature of Applicant

---

Date



**CRA CLEARANCE**

Please complete the attached form for tax clearance purposes:  
**FAX to the St. John's Taxation Centre at 709-754-5928.**

**The requested letter will indicate whether your business is in good standing with Canada Revenue Agency with respect to HST/GST, Payroll Taxes and Corporate Taxes.**

**Once you receive a reply from Canada Revenue Agency, please forward the letter directly the NLC for consideration with your application. Please fax the letter to 709-724-2250. (Attention: Liquor Express Sales Specialist/Business Development).**

**Please note that this takes approximately 4 weeks to be processed, so please complete and fax as soon as possible.**

Canada Revenue Agency  
St. John's Taxation Centre  
Fax Number: 709-754-5928

Please provide an account status comfort letter indicating the status and standing of the following business with respect to HST/GST, payroll tax, and corporate tax accounts.

Business Name: \_\_\_\_\_

Business Number: BN \_\_\_\_\_

Business Address: \_\_\_\_\_

\_\_\_\_\_

Business Telephone Number: \_\_\_\_\_

Name of Authorized Individual: \_\_\_\_\_





**Financial Institution Information Authorization**

The Newfoundland Labrador Liquor Corporation and/or its authorized representative is hereby authorized to obtain any information from the following Financial Institutions which it considers pertinent to my application for a Liquor Express store.

**Please Print**

**Financial Institution:** \_\_\_\_\_

Location: \_\_\_\_\_

Telephone #: \_\_\_\_\_ Fax #: \_\_\_\_\_

Contact Person: \_\_\_\_\_

**Financial Institution:** \_\_\_\_\_

Location: \_\_\_\_\_

Telephone #: \_\_\_\_\_ Fax #: \_\_\_\_\_

Contact Person: \_\_\_\_\_

Applicant(s):

\_\_\_\_\_

Last Name	Given Names
-----------	-------------

\_\_\_\_\_

Last Name	Given Names
-----------	-------------

\_\_\_\_\_  
Signature of Applicant

\_\_\_\_\_  
Signature of Applicant

\_\_\_\_\_  
Date



**SCHEDULE A**

**Liquor Express - Category "B" Requirements**

Estimated Annual Sales \$650,000 - 999,999

Estimated Opening Inventory Investment: \$125,000

**Minimum Linear Footage:**

Perimeter Spirit Shelving: 180 ft - 200 ft

Wine Island Fixture: 96 ft – 160 ft

Ready to Drink Cold Space: 40 ft

Walk-In Beer Room 100 sqft



**SCHEDULE B**

**OFFICER'S CERTIFICATE**

TO: NEWFOUNDLAND LABRADOR LIQUOR CORPORATION  
(the "NLC")

RE: \_\_\_\_\_ (Company Name) (the "Company")

I, \_\_\_\_\_ [name] being \_\_\_\_\_ [title] of the Company, after having made necessary investigations of corporate records and inquiries of other officers, directors, and senior personnel of the Company, hereby do solemnly declare as follows:

1. The Company was incorporated under the provisions of the [Corporations Act or equivalent in the jurisdiction] (the "Act") on the \_\_\_\_\_ day of \_\_\_\_\_, \_\_\_\_\_. A true and complete copy of the Certificate of Incorporation of the Company (the "Articles") and all amendments thereto are attached hereto, together with a current Certificate of Good Standing. The Articles have not been further amended and no proceedings have been taken or are pending to amend, surrender or cancel the same.
2. The following persons are the directors and/or officers of the Company who hold the office set out opposite their name:

Name

Position

\_\_\_\_\_

\_\_\_\_\_

\_\_\_\_\_

\_\_\_\_\_

\_\_\_\_\_

\_\_\_\_\_

3. The following persons are the shareholders of the Company who hold the shares set out opposite their respective names:

<u>Name</u>	<u>Number and type of shares held.</u>
_____	_____
_____	_____
_____	_____

4. No action has been taken by either the shareholders or directors of the Company to limit or restrict the powers of the directors, including the power to enter into contracts, borrow money and give security therefor, as conferred under the Act. There are no provisions in the Articles or by-laws of the Company or any unanimous shareholder agreement or declaration with respect to the Company which restricts, limits or regulates the powers of the Company or the directors of the Company to borrow money upon the credit of the Company, to issue, re-issue, sell or pledge debt obligations of the Company, to give guarantees on behalf of the Company, or to hypothecate, pledge, transfer, assign or subject to a security interest any of the present and future property, real and personal, movable and immovable, undertaking, rights and assets of the Company.
5. No proceedings are pending for the forfeiture of the Company's Certificate of Incorporation or for its dissolution, voluntarily or involuntarily.
6. The Company is duly registered, licenced and qualified and is up to date in the filing of all corporate and civil returns under the laws of Newfoundland and Labrador and any other jurisdiction where the nature of its business or the assets owned or leased by it so requires.
7. I have reviewed the terms of the Documents. Any director or officer who executes the Documents on behalf of the Company has full authority to so execute on behalf of the Company and to bind the Company with respect thereto.
8. The Company is not presently a party to any material litigation or proceedings and there is no litigation, or proceedings pending or threatened against the Company before any court, administrative board or agency, or any other tribunal and we know of no facts which might give rise to any such litigation or proceedings.
9. The Company has fully and adequately insured all of its property and assets to the full insurable value thereof with a reputable and established insurer.
10. There is no outstanding liability to any government or governmental or statutory agency or authority whereby any lien is outstanding or pending.
11. The Company has full capacity and power to own its properties, to carry on its business as the same is presently conducted, and execute and deliver the Documents.

12. The entry into, execution and delivery of, and the performance of the obligations under and pursuant to the Documents by the Company do not conflict with or result in the breach of or constitute a default under any bond, debenture, notice, mortgage, indenture, agreement or other instrument to which it is a party.

Dated this \_\_\_\_\_ day of \_\_\_\_\_, 20\_\_\_\_.

\_\_\_\_\_  
President & Secretary



**Appendix A - BUSINESS REFERENCE**

**Date:** \_\_\_\_\_

**To:** \_\_\_\_\_  
(Include Business Name)

**Attn:** \_\_\_\_\_

**Phone:** \_\_\_\_\_

**Fax Number:** \_\_\_\_\_

**From:** \_\_\_\_\_

**Attn:** \_\_\_\_\_

**Phone:** \_\_\_\_\_

**Fax Number:** \_\_\_\_\_

**As part of the review of the above applicant for a Liquor Express store, the Newfoundland Labrador Liquor Corporation requires the credit and business status of the applicant with your company. Please complete and return this document regarding the above referenced applicant at your earliest opportunity.**

- 1) Amount of Credit granted: \_\_\_\_\_
- 2) Annual business volume: \_\_\_\_\_
- 3) Term Credit (Payment): \_\_\_\_\_
- 4) Credit Rating: \_\_\_\_\_
- 5) Present Account Balance: \_\_\_\_\_
- 6) Status of Account(s): \_\_\_\_\_

**Additional Comments:**

---

---

\_\_\_\_\_  
Company Official Signature



**Appendix A - BUSINESS REFERENCE**

**Date:** \_\_\_\_\_

**To:** \_\_\_\_\_  
(Include Business Name)

**Attn:** \_\_\_\_\_

**Phone:** \_\_\_\_\_

**Fax Number:** \_\_\_\_\_

**From:** \_\_\_\_\_

**Attn:** \_\_\_\_\_

**Phone:** \_\_\_\_\_

**Fax Number:** \_\_\_\_\_

**As part of the review of the above applicant for a Liquor Express store, the Newfoundland Labrador Liquor Corporation requires the credit and business status of the applicant with your company. Please complete and return this document regarding the above referenced applicant at your earliest opportunity.**

- 1) Amount of Credit granted: \_\_\_\_\_
- 2) Annual business volume: \_\_\_\_\_
- 3) Term Credit (Payment): \_\_\_\_\_
- 4) Credit Rating: \_\_\_\_\_
- 5) Present Account Balance: \_\_\_\_\_
- 6) Status of Account(s): \_\_\_\_\_

**Additional Comments:**

---

---

\_\_\_\_\_  
Company Official Signature



**Appendix A - BUSINESS REFERENCE**

**Date:** \_\_\_\_\_

**To:** \_\_\_\_\_  
(Include Business Name)

**Attn:** \_\_\_\_\_

**Phone:** \_\_\_\_\_

**Fax Number:** \_\_\_\_\_

**From:** \_\_\_\_\_

**Attn:** \_\_\_\_\_

**Phone:** \_\_\_\_\_

**Fax Number:** \_\_\_\_\_

**As part of the review of the above applicant for a Liquor Express store, the Newfoundland Labrador Liquor Corporation requires the credit and business status of the applicant with your company. Please complete and return this document regarding the above referenced applicant at your earliest opportunity.**

- 1) Amount of Credit granted: \_\_\_\_\_
- 2) Annual business volume: \_\_\_\_\_
- 3) Term Credit (Payment): \_\_\_\_\_
- 4) Credit Rating : \_\_\_\_\_
- 5) Present Account Balance: \_\_\_\_\_
- 6) Status of Account(s): \_\_\_\_\_

**Additional Comments:**

---

---

\_\_\_\_\_  
Company Official Signature





**Wine Fixture shelving requirements.**

48" LONG SECTION

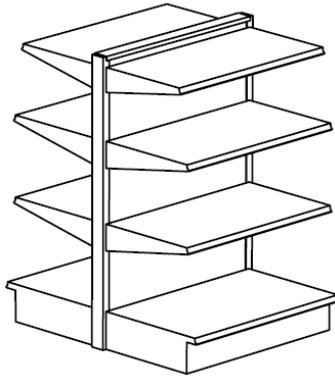
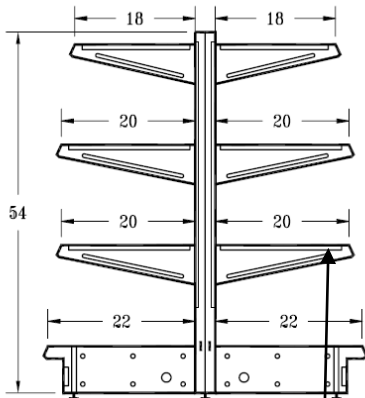

GENERAL SPECIFICATION
POST :
12 GAUGE - HSLA
BASE FOOT :
14 GAUGE - HSLA
FRONT KICK PLATE:
22 GAUGE
BASE SHELF AND REGULAR
PERFORATED SHELF:
22 GA
SHELF BRACKET:
12 GAUGE - HSLA
TOP CAP:
22 GA

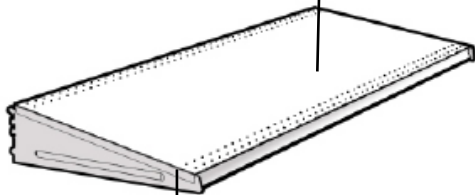

- Standard one-piece shelf with a 1 1/4 " steel ticket moulding on the front edge.

- Shelf made of 12 gauge steel, baked enamel finish and perforated.

**Perimeter (Spirits) shelving requirements.**

36" LONG SECTION

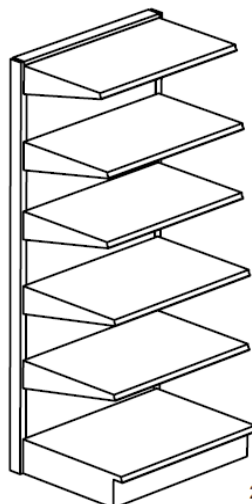
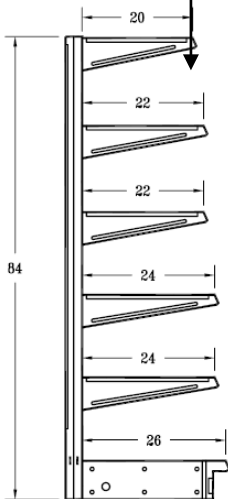

GENERAL SPECIFICATION
POST :
12 GAUGE - HSLA
BASE FOOT :
14 GAUGE - HSLA
FRONT KICK PLATE:
22 GAUGE
BASE SHELF AND REGULAR
PERFORATED SHELF:
22 GA
SHELF BRACKET:
12 GAUGE - HSLA
TOP CAP:
22 GA